

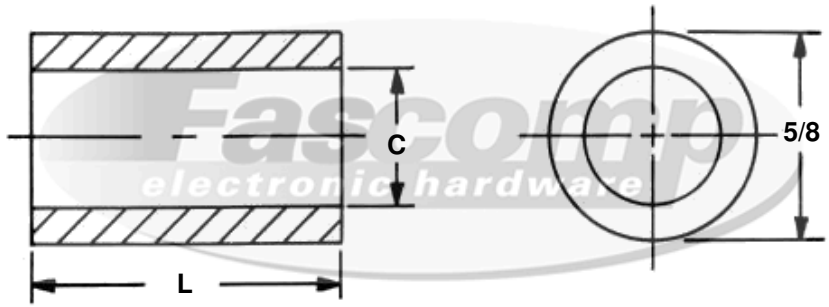

5/8 Round Spacers



Hex Code Table		
✓	FMXXXX	Length (L)
	FC1246	1/8
	FC1247	3/16
	FC1248	1/4
	FC1249	5/16
	FC1250	3/8
	FC1251	7/16
	FC1252	1/2
	FC1253	9/16
	FC1254	5/8
	FC1255	11/16
	FC1256	3/4
	FC1257	13/16
	FC1258	7/8
	FC1259	15/16
	FC1260	1
	FC1261	1-1/16
	FC1262	1-1/8
	FC1263	1-3/16
	FC1264	1-1/4
	FC1265	1-5/16
	FC1266	1-3/8
	FC1267	1-7/16
	FC1268	1-1/2
	FC1269	1-9/16
	FC1270	1-5/8
	FC1271	1-11/16
	FC1272	1-3/4
	FC1273	1-13/16
	FC1274	1-7/8
	FC1275	1-15/16
	FC1276	2

Create a part number:

Length	Clearance	Material	Finish
FCXXXX	XX	XX	XX
<div style="border-top: 1px solid black; border-bottom: 1px solid black; width: 100%;"></div>			

Hole Clearance Code (XX)		
✓	Code (XX)	C + .010
	6	.140
	8	.166
	10	.192
	12	.218
	25	.252
	31	.315
	38	.380

Material		
✓	Material Code (XX)	
	A	Aluminum
	B	Brass
	S	Steel
	SS	Stainless Steel
	N	Nylon

✓	Compatible Finish (XX)	
	A, B, S, SS	0 - Plain
	B, S	5 - Nickel Plate (QQ-N-290)
	A	6 - Iridite #14 Gold (MIL-C-5541E)
	A	7 - Iridite Clear (MIL-C-5541E)
	A	9 - Alodine 1200
	B, S	12 - Zinc Clear (ASTM-B-633)
	B, S	16 - Electro Tin (MIL-T-10727 TYPE 1)
	SS	20 - Passivation (MIL-F-14072D)
	A	22 - Clear Anodize (MIL-A-8625-TYPE2) (Sulphuric) Hot Water Seal (Clear)
	A	24 - Black Anodize (MIL-A-8625)
	B, S, SS	26 - Black Oxide
	B, S	28 - Zinc Yellow (ASTM-B-633)



Tolerances Unless otherwise Specified
 .xxx +/- .005
 .xx +/- .010
 Angular +/- 1 Degree
 Linear +/- .005
Break all sharp edges

Source Control Drawing:
 To be produced by
 Fascomp Electronic Hardware

This document is the property of Fascomp Inc. and shall not be reproduced, distributed, or used as a basis for manufacturing without written permission from Fascomp Inc.